



Model NR3XL

Water Pressure Reducing Valve with Integral By-Pass Check Valve and Strainer

Application

Ideal for use where Lead-Free* valves are required. Designed for installation on potable water lines to reduce high inlet pressure to a lower outlet pressure. The integral strainer makes this device most suitable for residential and commercial water systems that require frequent cleaning of sediment and debris. The direct acting integral by-pass design prevents buildup of excessive system pressure caused by thermal expansion. The balance piston design enables the regulator to react in a smooth and responsive manner to changes in system flow demand, while at the same time, providing protection from inlet pressure changes.

Standards Compliance

- ASSE® Listed 1003
 - IAPMO® Listed
 - CSA® Certified
 - NSF® Listed - Standard 61 & 372*
 - Certified to NSF/ANSI 372* by IAPMO R&T
- *(0.25% MAX. WEIGHTED AVERAGE LEAD CONTENT)

Materials

Main valve body	Low Lead Cast bronze ASTM B 584
Bell housing	UV resistant polymer composite
Internals	Stainless steel, 300 Series
Stem	Low Lead Brass
Elastomers	EPDM (FDA approved) Buna nitrile (FDA approved)
Cartridge	Delrin™ (NSF Listed)
Springs	302 Stainless Steel
Strainer screen	300 Series Stainless Steel

Features

Sizes:	1/2", 3/4", 1", 1-1/4", 1-1/2", 2"
Max. working water pressure (1/2" - 1-1/4")	400 psi
Minimum inlet pressure =	80 psi as per UPC Code
Max. working water pressure (1-1/2" - 2")	300 psi
Max. working water temperature	140°F
Reduced pressure range (1/2" - 1-1/4")	15 to 75 psi
Reduced pressure range (1-1/2" - 2")	25 to 75 psi
Factory preset	50 psi
Threaded connections (FNPT)	ANSI B1.20.1
Copper connections (FC)	ANSI B16.22
CPVC tailpiece: Max. hot water temp.	140°F @ 100 psi
Cold water rated temp.	73.4°F @ 400 psi

Dimensions & Weights (do not include pkg.)

SIZE		CONNECTIONS	DIMENSIONS (approximate)								WEIGHT	
in.	mm		A		B		C		D		lbs.	kg
1/2	15	SINGLE UNION	4 3/8	111	6 1/4	159	1 1/8	29	2 1/2	64	3	1.5
1/2	15	LESS UNION	3 1/2	89	6 1/4	159	1 1/8	29	2 1/2	64	3	1.5
1/2	15	DOUBLE UNION	5 1/4	133	6 1/4	159	1 1/8	29	2 1/2	64	3	1.5
3/4	20	SINGLE UNION	4 7/16	113	6 1/4	159	1 1/8	29	2 1/2	64	3	1.5
3/4	20	LESS UNION	3 1/2	89	6 1/4	159	1 1/8	29	2 1/2	64	3	1.5
3/4	20	DOUBLE UNION	5 3/8	137	6 1/4	159	1 1/8	29	2 1/2	64	3	1.5
3/4	20	DOUBLE MALE METER	3 5/8	92	6 1/4	159	1 1/8	29	2 1/2	64	3	1.5
1	25	SINGLE UNION	4 15/16	125	6 1/4	159	1 1/8	29	2 1/2	64	4	2
1	25	LESS UNION	4	102	6 1/4	159	1 1/8	29	2 1/2	64	3.5	1.6
1	25	DOUBLE UNION	5 15/16	151	6 1/4	159	1 1/8	29	2 1/2	64	4.5	2.1
1	25	DOUBLE MALE METER	4	102	7 3/4	197	1 3/16	30	3	76	4	2.0
1 1/4	32	SINGLE UNION	6 3/16	157	7 3/4	197	1 3/16	30	3	76	5.5	2.5
1 1/4	32	LESS UNION	5	127	7 3/4	197	1 3/16	30	3	76	5	2.3
1 1/4	32	DOUBLE UNION	7 3/8	187	7 3/4	197	1 3/16	30	3	76	6	2.7
1 1/2	40	SINGLE UNION	6 5/16	160	8 1/2	216	1 3/4	45	3 3/4	95	6.6	3
1 1/2	40	LESS UNION	5	127	8 1/2	216	1 3/4	45	3 3/4	95	5.5	2.5
1 1/2	40	DOUBLE UNION	7 1/2	191	8 1/2	216	1 3/4	45	3 3/4	95	7.7	3.5
2	50	SINGLE UNION	6 1/4	159	8 1/2	216	2	51	3 3/4	95	8.1	3.7
2	50	LESS UNION	5	127	8 1/2	216	2	51	3 3/4	95	6.7	3
2	50	DOUBLE UNION	7 1/2	191	8 1/2	216	2	51	3 3/4	95	9.5	4.3



Options

(Suffixes can be combined)

- standard with single union FNPT connection and 20 mesh strainer screen
- C - with FC (copper sweat) union connection
- DM - with double male 3/4" & 1" meter threads connection with SS spring & sealed cage
- G - tapped with gauge
- DU - with double union connection (FNPT)
- DULU - with 2 integral FNPT connection (no union)
- PEX - with male barbed connection tailpiece for crossed-linked polyethylene tubing
- PEXF1960- with male barbed connection PEX tailpiece conforming to ASTM F1960
- SC - with ss adjustment bolt and lock nut with ss spring for below-ground installations
- P - tapped and plugged for gauge
- CPVC - CPVC tailpiece connection (3/4" - 1")
- HRSC - High Range 15-150 psi (1/2"-1-1/4" only) with sealed cage
- DUPF - with 2 Z-Bite™ push fit tailpiece connection 250 psi max pressure (1/2" - 1" only)
- DUPR - with 2 Z-Press™ press fit tailpiece connection 250 psi max pressure (3/4" - 2" only)
- DULUPF- with 2 integral Z-Bite™ push fit connections 250 psi max pressure
- DULUPR- with 2 integral Z-Press™ press fit connections 250 psi max pressure

Accessories

- Repair kit
- 1" BR4DUSPC Special plastic spacer nipple
- 1-1/4" BR4DUSPC Steel pipe
- 1-1/2" NR3DUSPC Steel pipe
- 2" NR3DUSPC Steel pipe
- TPKXL Lead-Free Tailpiece kit
- TPKXLPF Z-Bite™ push fit Tailpiece kit
- TPKXLPF 250 psi max pressure (1/2"-1" only)
- TPKXLPF Z-Press™ press fit Tailpiece kit
- TPKXLPF 250 psi max pressure (3/4"-2" only)

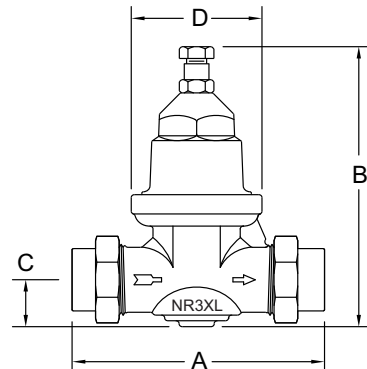

Flow Characteristics

◇ Rated Flow (established by approval agencies)

MODEL NR3XL 1/2", 3/4" & 1" (STANDARD & METRIC)

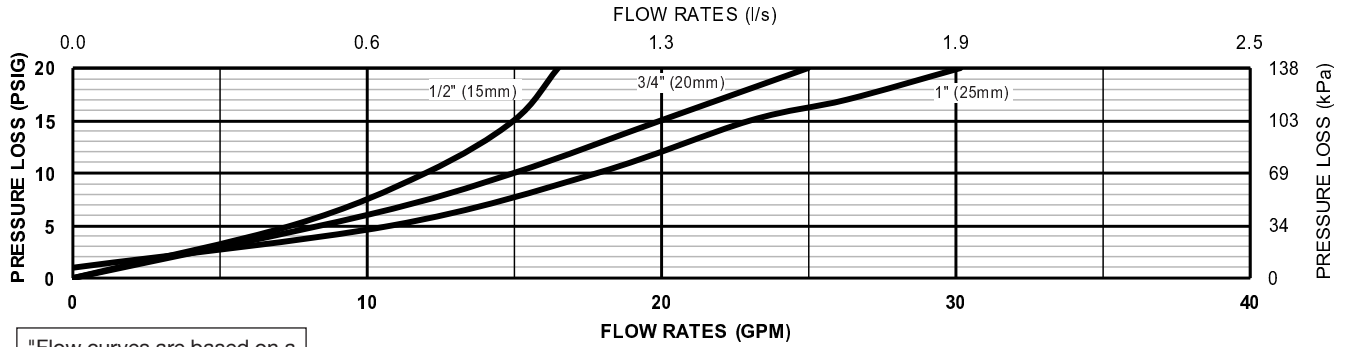

MODEL NR3XL 1-1/4", 1-1/2" & 2" (STANDARD & METRIC)

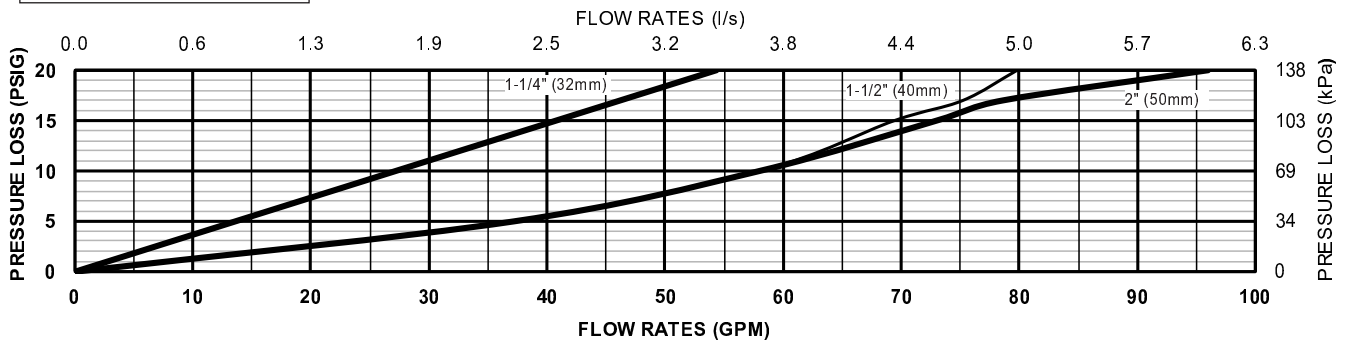

Typical Installation

Local codes shall govern installation requirements. Unless otherwise specified, the assembly shall be mounted in accordance with the latest edition of the Uniform Plumbing Code. The Model NR3XL may be installed in any position. If installed in a pit, vault, or inside application, specify the "SC" sealed cage option. The assembly shall be installed with sufficient side clearance for testing and maintenance. Multiple installations are recommended for wide demand variations or where the desired pressure reduction is more than 4 to 1 (ie: 200 psi inlet reduced to 50 psi outlet). **CAUTION:** Anytime a reducing valve is adjusted, a pressure gauge must be used downstream to verify correct pressure setting. Do not bottom adjustment bolt on bell housing.

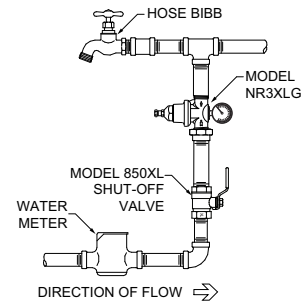

OUTDOOR INSTALLATION

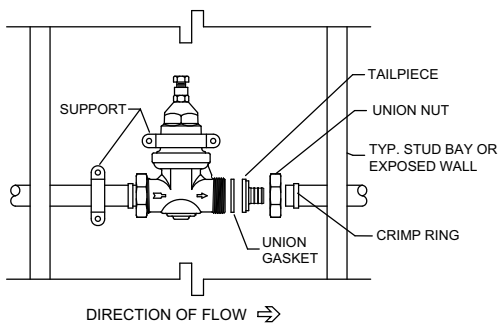

NR3XL DUPEX INSTALLATION

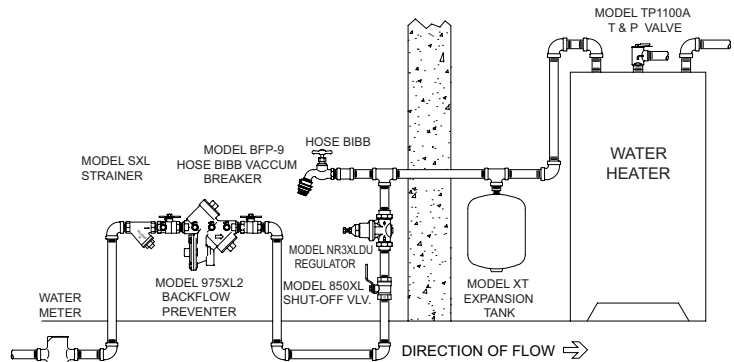

TYPICAL INSTALLATION

Specifications

The Water Pressure Reducing Valve shall be certified to NSF/ANSI 372 and ASSE® Listed 1003, available with single union, double union and less union end connections. The main body shall be low lead cast bronze (ASTM B 584) alloy. The bell shall be composite plastic. The cartridge shall be NSF® Listed acetal and incorporate an integral seat. The seat disc elastomer shall be NSF® Listed EPDM. The assembly shall be accessible for maintenance without removing the device from the line. The Water Pressure Reducing Valve shall be a ZURN WILKINS Model NR3XL.